

APPROXIMATE WEIGHT: 5265 LBS.

PLAN

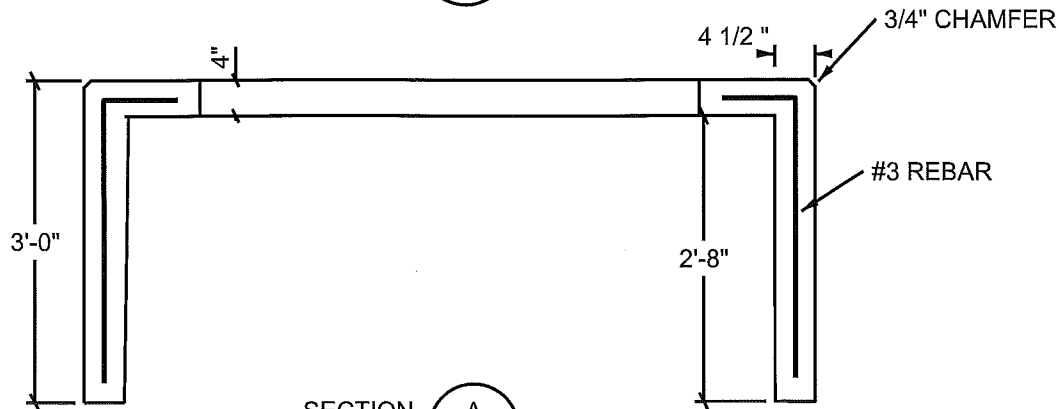

SECTION

REBAR & MESH					
BAR#	MARK	REBAR LIST			
		QTY.	BEND	LENGTH	WEIGHT
3		27		8'-29"	
3		8		1'6"X5'11"X1'6"	
3		8		6'-6"	
3		2		1'6"X5'6"X1'6"	
3		2		5'6"	

	1122 BRADWAY ROAD. NORTH POLE, AK.99705 PH: (907) 488-9763 FAX: (907) 488-8300	
	SCALE: NO SCALE	DRAWN BY: T.E.C.
DATE 1/22/2010	REVISED: 2/10/2010	
UM1-1F/SUM1-F 75"X82"X36"		